



The automated **PTG S3** powder testing system is used to measure the flow behaviour of granules and powders in compliance with the monographs of the EP <2.9.36> and USP <1174> Pharmacopoeia and ISO 4324 standards. This instrument is suitable for testing powder flow time, the measurement of the cone angle of the collected powder mound, measuring the weight, calculating the density and the volume of the powder cone as well as the Flowability Index which is measuring the flow time of 100 g of sample through a specified pouring nozzle, usually 10, 15 and 25mm.

### ***Why Measure the Flow Properties of Powders?***

It has been estimated that over 50% of the materials used in all industrial applications were at some stage in a powder form. These powders need to be transported, injected, propelled and be able to pass through various process stages before they achieve their final form. This final form may be a tablet, a suspension or indeed a powder formulation. The need to be able to measure, control or test for reproducible powder flow has been well established in many industrial applications.

For example powder flow characteristics are important for:

- Reduction in cost of raw process materials: reject bad batches before processing
- Maintenance of the optimum formulation for the process concerned
- Reduction in process costs
- Maintain the quality and consistency of the final product
- Maintain process efficiency and costs by optimisation of product storage, packing, handling and transportation
- Maintain powder quality from different suppliers or from the same supplier over a long time period
- Development of new processes where powders are required to be formulated into end products
- Check moisture effects: use of powders in open systems in different climates
- Investigating and maintaining the quality of dry mixes

In processes, which rely on powder and / or powder mix integrity, the need to have the correct powder flow characteristics is paramount. These powder mixes have to be formulated, mixed and certainly transported. Transportation, even over small distances can easily lead to classification of sorts such that “fines” may drop out and alter the particle size distribution and hence the flow characteristics.

For example we can look at formulated mixtures, which are fed into tableting machines: these powders need to flow in exactly the same way from batch to batch. Generally, the active ingredients are materials that have no natural flow properties. They are sticky (cohesive) and prone to agglomeration. Additionally, the requirement of active material in ever decreasing dosages means that the active must be able to be dispersed in a non-active medium (normally made up of well established and mainly natural products) in a reproducible way in the mixers prior to the introduction of the formulation into the tablet press. The fact that the non-active materials such as MCC (Micro Crystalline Cellulose), starch and lactose are natural products means that these materials are prone to variations in particle size, agglomeration, surface area, and so on, depending on the product source. Then we have to consider the effect of the introduction of materials such as silica (e.g., Aerosil 300), starch, etc. which aid the flow of these normally quite stubborn powders. The need to control each of the components as well as the final mix now becomes clear. Control of this type can save a lot of time, wasted money and resources if checks are made at the right time on these component powders.

Additional advantages can also be listed:

- Improve product consistency from batch to batch
- Keep tight control of component powders, especially if they are natural products
- Compare sources of powdered products
- Easy method to achieve quality control on bulk incoming component products
- Easy method for the control of dry and wet mixing, tableting, granulating, and capsule filling
- Prediction of powder transport through conveyors, air lifts and in silos
- Prediction of powder suitability for capsule and bottle filling
- Prediction of product settling during transport, so called classification
- Prediction of powder influence on tablet hardness and solid dosage form stability

- Prediction of powder influence on tablet disintegration and friability

Areas of use for powder flow characterisation:

- Pharmaceutical Granulation, micronising, Tablets and other solid dosage forms
- Abrasives Ceramics, metallic powders and grinding pastes
- Catalysts Powders for extrudates, catalyst rings, and finely divided metals
- Chemicals Bulk chemicals, fine chemicals
- Printing Pigments, toners and binders
- Washing powders Powdered surfactants, bulking agents and granulates
- Fertilisers Extrudates, granulates, powdered pesticides

**Operation Principle of the PTGS3...**

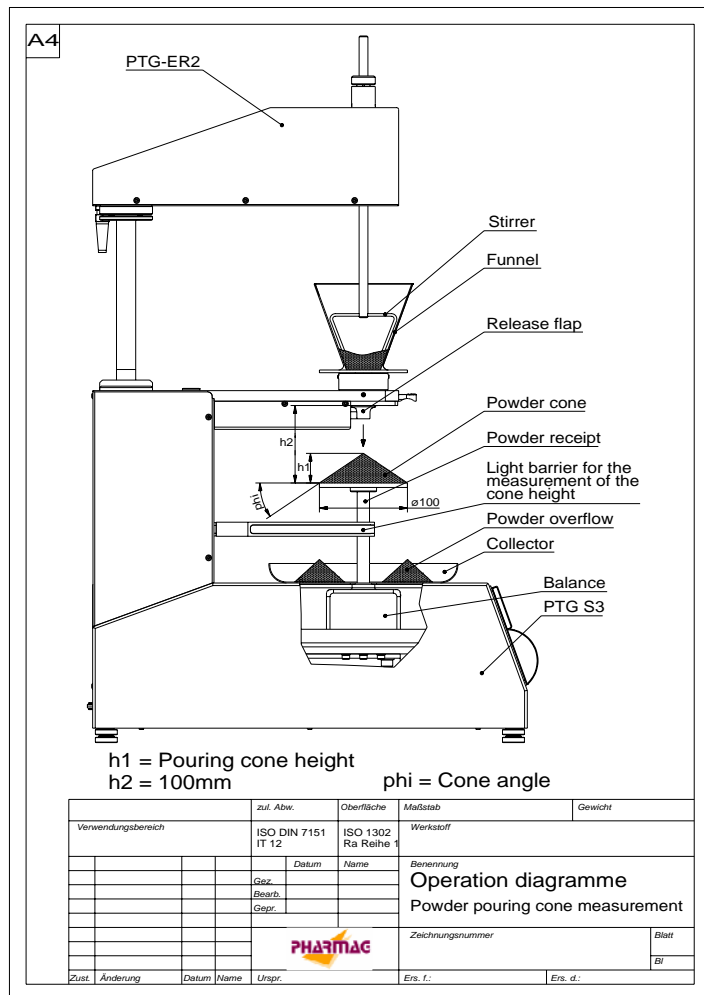

The design is compliant to the ISO 4324 (12/83) standard and EP <2.9.36> and USP <117>. A conical funnel, which can be equipped with different pouring nozzles, takes the sample to be tested. A built-in analytical Sartorius balance cell takes the product collecting dish. The PTG-ER electrical stirrer may be used for those powders, which do not flow due to the high percentage of fines.

Enter product information using the alphanumeric keyboard of the instrument. Select the test program you want to use, Flow Time - Cone Angle - Volume - Flow-Chart - Density - Flowability and start the test. Depending on the powder possibly a stirrer, PTG-ER, is needed as most of the pharmaceutical material has such a high amount of fine particles that it won't start and flow without any assistance. When the test is started the funnel is opened and two IR sensors detect the powder flow, this will start the timer to measure Flow Time and to record the Flow Chart.

The product itself is collected at a 100 mm diameter dish and forms a cone. If there is no more powder flow the funnel is closed and the movable measuring arm which holds the 2 IR

## Automated Powder Analyzer - Type PTG S3

sensors starts to measure the height of the cone up to the tip. As the surface of the collecting dish is completely filled the cone angle can be calculated and displayed.

The test should be repeated (in accordance to the ISO 4324 five times) and the deviation of results should not exceed 5%.

The test results are displayed at the LCD display of the PTG S3. Using the built-in thermo printer a test report and powder flow-chart will be printed including descriptive information of the product.

To measure the FLOWABILITY test as per the monographs of the EP <2.9.36> and USP 1174 - flow through an orifice> Pharmacopoeia the test is automatically stopped as soon as 100 mg of sample have been collected inside a suitable plastic beaker. In addition to the Flowability factor (100 mg/t) the powder flow chart can be printed.



The standard PTG S3 instrument comes with all attachments to measure flow-time, cone angle and flowability in compliance to the current USP and EP Pharmacopoeia. Different pouring nozzles from 4 - 10 mm can be used to test the product. A stirrer can be used to force non-flowing product through the selected pouring nozzle.

The PTG S3 powder testing system includes also a built-in analytical Sartorius balance cell, which extends the instrument use to test powder flowability, density and volume. Additionally, a graph can be plotted on the built-in printer showing the flow behaviour of the sample under test. Using the conical stainless steel funnel as described in the EP <2.9.36> monograph and us the changeable nozzles of 10, 15 and 25 mm, the cone angle can also be tested. If smaller diameter nozzles shall be used we supply an Adapter Ring which allows the use of pouring nozzles from 4 to 10 mm.

Up to 10 tests can be done and used to calculate statistics including mean values of all selected test parameters. The data and results are displayed at the LCD display, presented as hard copy on the built-in printer or transmitted via RS-232 interface to any external data collection system.



This instrument is widely used to compare batches of powders perhaps supplied by the same manufacturer over a period of time or for similar materials provides by different suppliers. The flow characteristics can be easily and quickly determined as a QC tool for inter- batch reproducibility, as this may have a distinct bearing on the ease of production especially if powders are capable of agglomeration and cohesion over time.

**PHARMA TEST AG**  
Siemensstrasse 5  
D-63512 Hainburg (GER)



+49 6182 9532-600  
+49 6182 9532-650  
email@pharma-test.de  
www.pharma-test.com



**Test smaller volumes....**

For smaller volumes a 10ml Funnel and a smaller sample collecting dish are available. This optional accessory can be used with pouring nozzles from 4 to 10 mm diameter. A suitable stirring shaft completes the set.

The PTG S3 analysis:

- Powder Flow Time of a pre defined mass
- Powder cone volume
- Powder cone density
- Cone Angle (Angle of Repose EP <2.9.36> - USP <1174>)
- Flowability of 100 mg of product EP<2.9.36> USP <1174>
- Amount of sample (mg in a preset time)
- Flow Chart of sample (mg/time)

Instrument Qualification Program:

- validate timer
- validate angle measurement
- set time and date
- show firmware release

Technical Data

Display:	LCD Display
Keyboard:	Alpha-numerical and function keys
Key entries:	12 digit product code 12 digit batch number
Volume of the st. steel cone:	Approx. 450 ml
Range for cone angle*:	1.0° to 45.0 °
Range for "flowability" test*:	0.1 sec. to 999 sec. - mass: 100 g
Range for flow time test*:	0.1 sec. to 999 sec.
Cone density*:	0.000 g/ml <sup>-1</sup> to 6.0 g/ml <sup>-1</sup>
Cone weight*:	1 mg to 325 g
Cone volume*:	0.1 ml to 275 ml
Interface:	RS-232 serial interface
Printer:	built-in Thermo Printer and/or external Parallel printer port
Instrument housing:	Stainless steel to meet GLP requirements
Included documentation:	GLP compliant IQ/OQ Documentation

\* theoretically maximum measurable data by the built-in electronics

## Automated Powder Analyzer - Type PTG S3

### Options:

- 10 ml small volume test set, includes POM funnel, stirrer, sample collecting dish, validation cone
- Dust Hood made from brown coloured Plexiglas, includes front door, vacuum exhaust connection tube



### PTG S3 Weights and Dimensions

Net weight:	30 kg
Gross weight:	43 kg
Packaging:	900 mm x 650 mm x 750 mm

We reserve the right to make technical changes without any prior notice